



CN 111501533 B
2022. 01. 04

202010355433. 4

2020. 04. 29

CN 111501533 A

2020. 08. 07

230009

193

CN 1570332 A, 2005. 01. 26

CN 104233964 B, 2016. 05. 18

CN 103485481 A, 2014. 01. 01

CN 206957057 U, 2018. 02. 02

CN 102660927 A, 2012. 09. 12

CN 105821758 A, 2016. 08. 03

CN 201704862 U, 2011. 01. 12

CN 2595929 Y, 2003. 12. 31

KR 20150031089 A, 2015. 03. 23

() 34118

(2006. 01)

E01D 101/40(2006. 01)

权利要求书2页 说明书5页 附图2页

FRP

FRP

FRP

GFRP

GFRP

CFRP

FRP

FRP

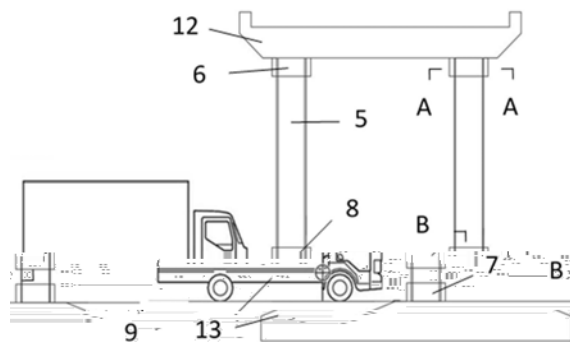

FRP

FRP

CN 111501533 B

1.	FRP							FRP
GFRP	1	CFRP	2	GFRP	3		FRP	4
FRP	4				6	7		8
S1.			5					
S2.					5			5
S3.								
A.			5					5
					5			
	5							
			5		6	7		8
B.			5					
					5	6	7	8
C.			5					5
8			5					
5							5	250mm
S4.	A				FRP	4		
5							5	
CFRP	2							
CFRP	2							
	B				FRP	4		
5							5	
CFRP	2							
	C							1
4		CFRP	2					FRP
		5	6	7				500mm
FRP	4		5					8
5								
S5.							CFRP	2
GFRP	1	GFRP	3					
2.		1			FRP			
		S2_S5						
3.		1			FRP			
		S2						
4h								

4. 1 FRP
S5

S51. 10 10

S52. 10

10

S53.

GFRP 1

S54. GFRP 1 GFRP 1
CFRP 2

S55. CFRP 2

CFRP 2 CFRP 2

CFRP 2 CFRP 2

S56. CFRP 2

GFRP 3 GFRP 3

5. 4 FRP
S51_ S56

6. 4 FRP
GFRP 1 CFRP 2 GFRP 3
5 5
S

FRP

Al mandsbury

FRP(Fi ber Rei nforced Pol ymer)

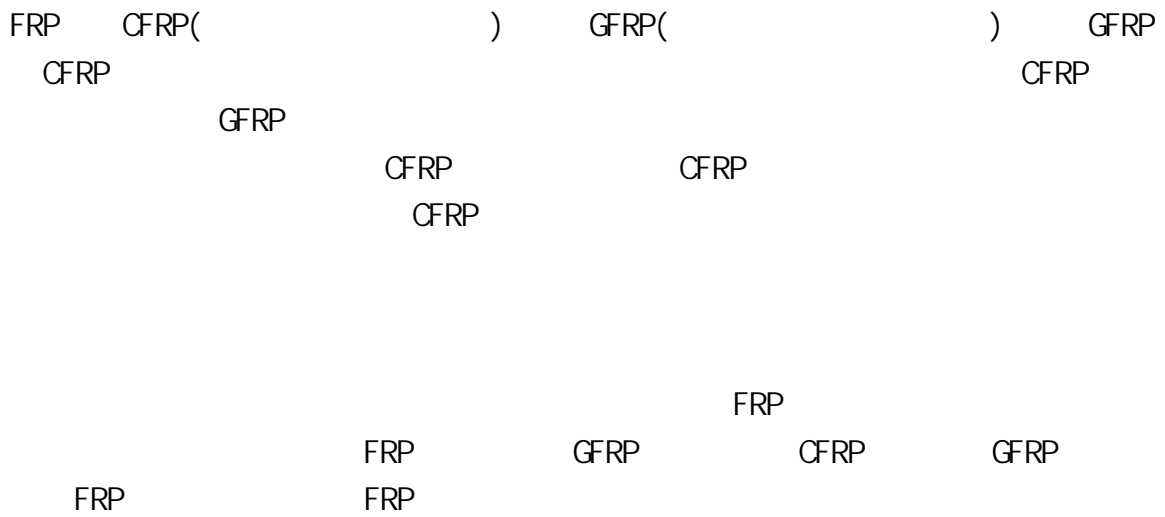

- S1.
- S2.
- S3.
- A.

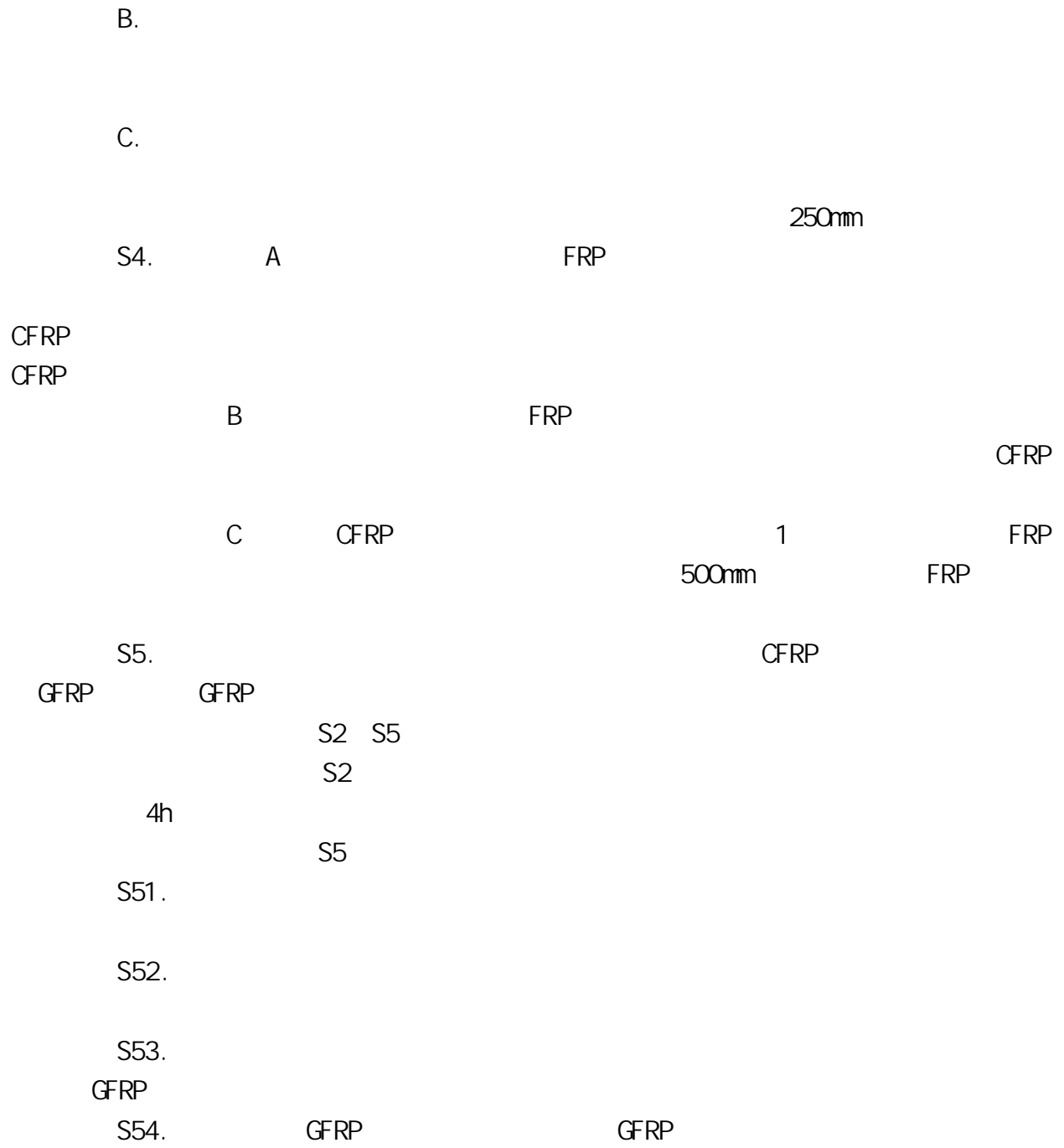

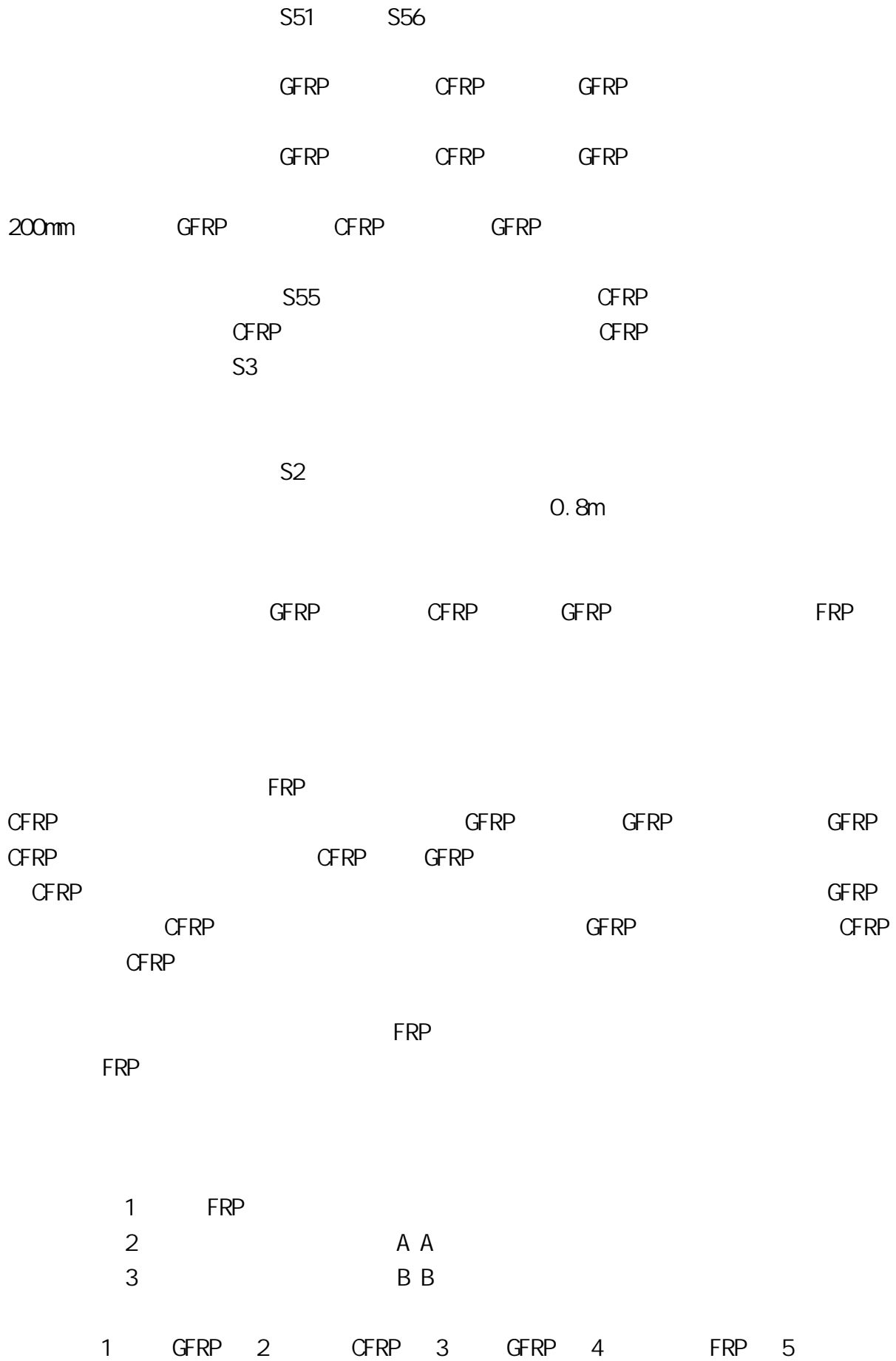

6	7	8		9	10	11		12
---	---	---	--	---	----	----	--	----

13

	1 3			5(600mm		12mm)		
			8.5t					
8.5t	9 140km/h				5			
			8.5t	9 140km/h			5	
		8			CFRP		1	
6	7	8	FRP				500mm	6
	5	12		7		5		13
	8		5					
	5		0.8m					
		5	10				10	
			10					

				10				
		GFRP 1						
	GFRP 1					CFRP 2		2
	CFRP 2					GFRP 3		3
GFRP 3								
		GFRP 1		CFRP 2		GFRP 3		
FRP 4	FRP 4							5
	GFRP 1	CFRP 2		GFRP 3				
5				5				200mm
GFRP 1	CFRP 2	GFRP 3				5		
		LS DYNA				5		FRP 4
	8.5t	9						
FRP 4		5						

	1 3			5(600mm		12mm)		
			40t					40t
9 140km/h					5			
			40t	9 140km/h				

7

5 40t 9
 20t 5 20t
 9 140km/h 5 5
 5 4h 5
 6 7 8 FRP
 4 5
 5 CFRP 2 5
 8 500mm FRP 4 6 7
 500mm CFRP 3 1 2
 6 7 8 6 5
 7 5 13
 8 12 5 8
 0.8m 5
 5 10 10
 10 10
 10
 GFRP 1
 GFRP 1 CFRP 2
 CFRP 2 GFRP
 3 GFRP 3
 GFRP 1 CFRP 2 GFRP 3
 FRP 4 FRP 4 5
 GFRP 1 CFRP 2 GFRP 3 5
 CFRP 2 GFRP 3 200mm GFRP 1
 LS DYNA 5 FRP 4
 40t 9 140km/h
 FRP 4 5
 5

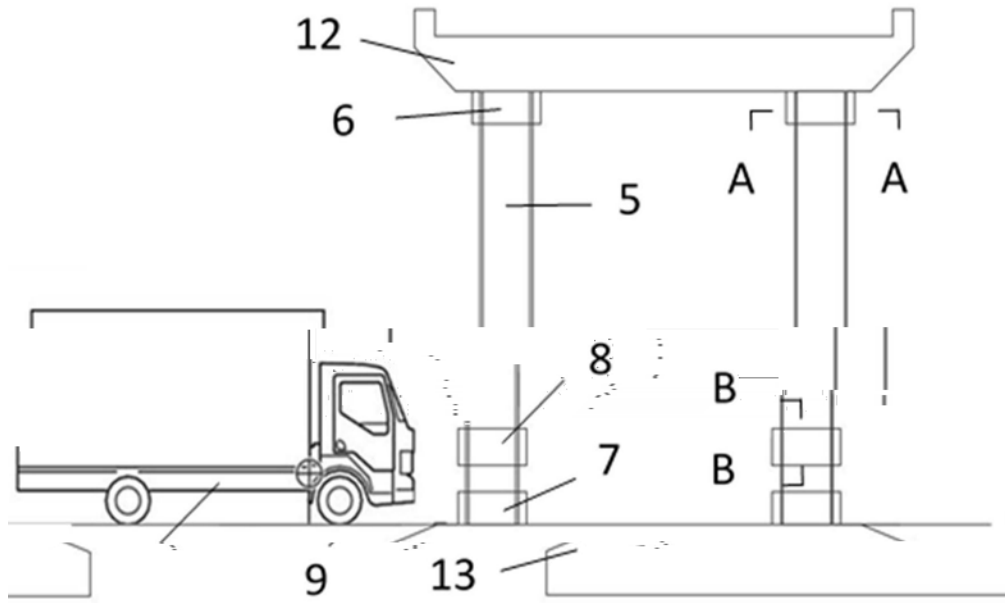

1

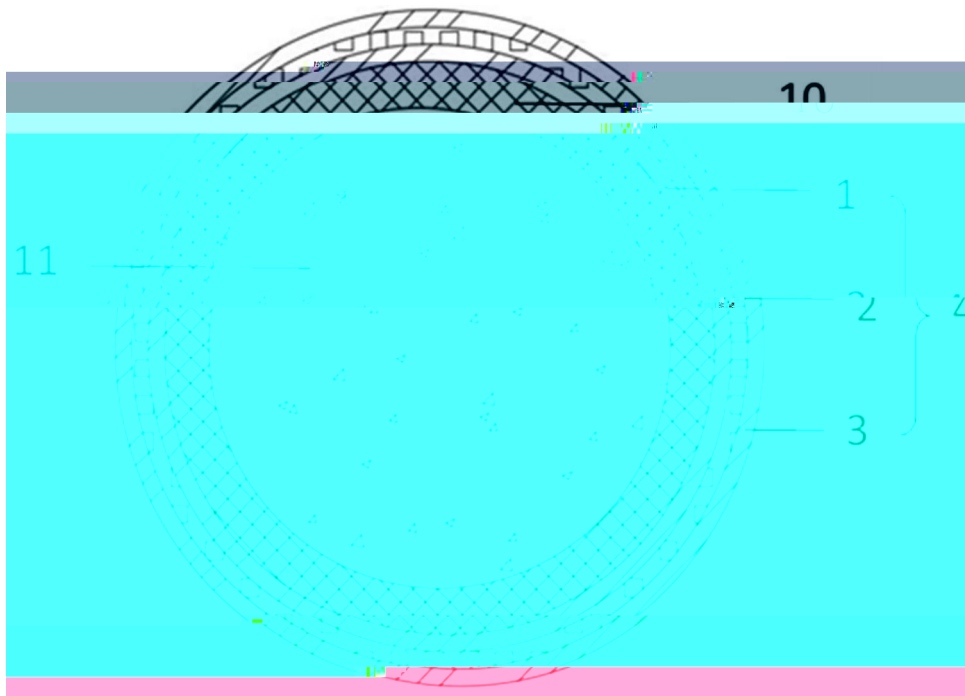

2

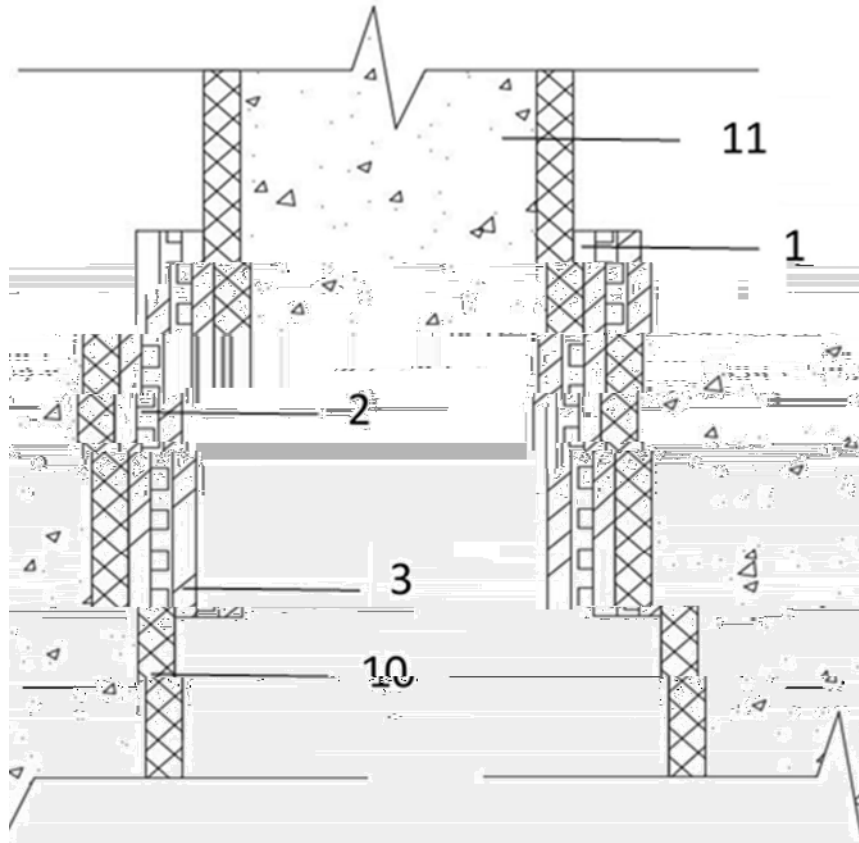

3